



Refrigerated Deli Case

ECD2-CG

Features

- * High-quality aluminum lining interior with stainless steel floor
- * Black steel body with stainless steel top
- * Gravity cooling system to prevent food dehydration
- * Self-evaporation water tray
- * 2 double layer glass sliding rear access doors
- * Rounded corners for easy cleaning
- * LED interior lighting
- * 4 heavy-duty epoxy coated shelves (2 levels)
- * Dixell digital temperature controller
- * Interior temperature range: 0°C - 5°C



Technical Drawing

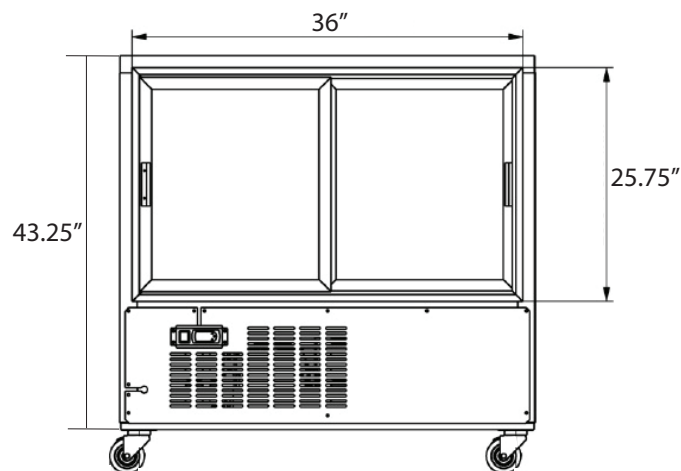
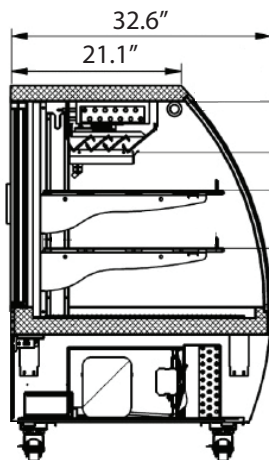

Model	Dimension W x D x H	Weight (lbs / kg)
ECD2-CG3	36" x 32.5" x 43.25"	298/135
ECD2-CG4	47".3 x 32.5" x 43.25"	386/175

Voltage

- ECD2-CG3 : 110V / 1ph / 60 Hz / 4.68 A
- ECD2-CG4 : 110V / 1ph / 60 Hz / 3.12 A